



NEW LED
WARNING LAMPS



REFERENCE:
LW0042

COUNTRY OF ORIGIN: PRC

WARNINGS FOR THE USER:

Warning!

- Do not look directly into the light - it may cause damage or even loss of vision.

- Install only in specialized workshops or professional services.

- Use in open space only.

- Use in accordance to the purpose.

LED STROBE LAMP 7W AMBER R10 R65

PHOTO AND TECHNICAL DRAWING:

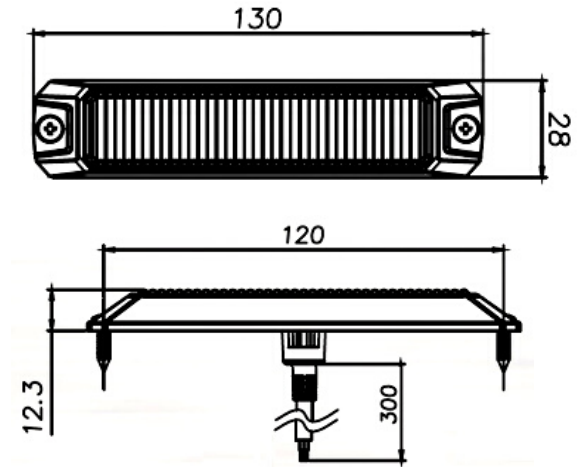

TECHNICAL SPECIFICATIONS:

MATERIAL	LED QUANTITY	MOUNTING	WIRE	FUNCTION	WATT	VOLTAGE	CERTIFICATES	PACKING/WEIGHT
» Lens: PC » Housing: AL	» 6	» screw	» 300mm	» 1 warning flash	» 7W	» 12V/24V	» ECE R10 » ECE R65	» cart. dim: 140x35x55mm » lamp weight: 79g » 50 pcs/bulk box

INSTALLATION INSTRUCTIONS:

- It should be used exclusively in accordance with intended use.
- Mount exclusively in specialized workshops.
- The connection between the lamp and vehicle's installation should be isolated with heat-shrink tube, or, alternatively, with isolating tape, to avoid getting water and moisture to the copper wire of the lamp, which can damage electronic components. When it comes to lamp and plug, the plug should be mounted safely.
- Do not cut off tinned ends.
- Lamps must be installed only in accordance with UNECE regulations

We reserve the right to change technical data and any errors. Photos and specifications are for reference only, and the actual product may vary slightly. Reproduction in whole or parts of the catalog without written authorization is prohibited.



www.truck-kamar.pl



REFERENCE:
LW0043

COUNTRY OF ORIGIN: PRC

WARNINGS FOR THE USER:

Warning!

- Do not look directly into the light - it may cause damage or even loss of vision.

- Install only in specialized workshops or professional services.

- Use in open space only.

- Use in accordance to the purpose.



www.truck-kamar.pl

LED STROBE LAMP 10W AMBER R10 R65

PHOTO AND TECHNICAL DRAWING:



TECHNICAL SPECIFICATIONS:

MATERIAL	LED QUANTITY	MOUNTING	WIRE	FUNCTION	WATT	VOLTAGE	CERTIFICATES	PACKING/WEIGHT
» Lens: PC » Housing: AL	» 4	» screw	» 300mm	» 1 warning flash	» 10W	» 12V/24V	» ECE R10 » ECE R65	» cart. dim: 60x60x85mm » lamp weight: 88g » 50 pcs/bulk box

INSTALLATION INSTRUCTIONS:

- It should be used exclusively in accordance with intended use.
- Mount exclusively in specialized workshops.
- The connection between the lamp and vehicle's installation should be isolated with heat-shrink tube, or, alternatively, with isolating tape, to avoid getting water and moisture to the copper wire of the lamp, which can damage electronic components. When it comes to lamp and plug, the plug should be mounted safely.
- Do not cut off tinned ends.
- Lamps must be installed only in accordance with UNECE regulations

We reserve the right to change technical data and any errors. Photos and specifications are for reference only, and the actual product may vary slightly. Reproduction in whole or parts of the catalog without written authorization is prohibited.



REFERENCE:
BLK0028

COUNTRY OF ORIGIN: PRC

WARNINGS FOR THE USER:

Warning!

-Do not look directly into the light - it may cause damage or even loss of vision.

-Install only in specialized workshops or professional services.

- Use in open space only.

- Use in accordance to the purpose.

LED WARNING LIGHTBAR 930X220 R10 R65 TA2

PHOTO AND TECHNICAL DRAWING:

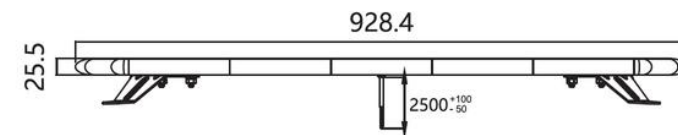
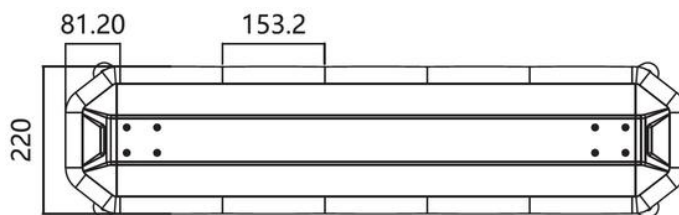
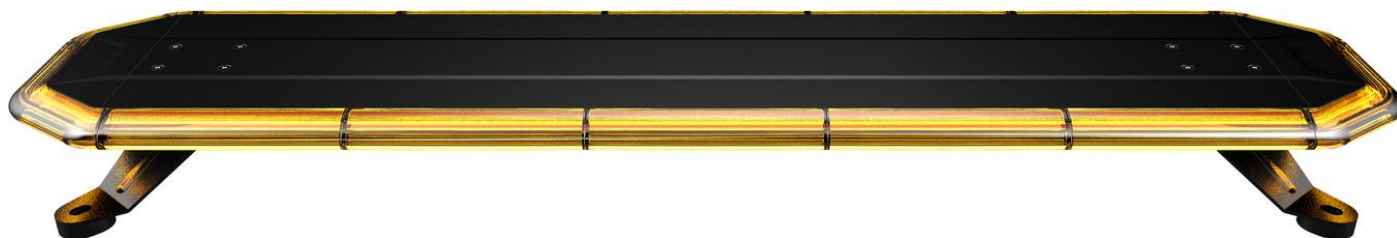

TECHNICAL SPECIFICATIONS:

MATERIAL	LED QUANTITY	MOUNTING	CABLE	FUNCTION	WATT	VOLTAGE	CERTIFICATES	PACKING/WEIGHT
» Lens: PC » Housing: AL	» 16	» screws	» 5000mm	» 1 warnings flashes, » two level of intensity, day and night	» 152W	» 12V/24V	» ECE R65 » ECE R10	» cart.dim.: 1180x300x50 mm » lamp weight: 5820g » 1 pc/bulk box

INSTALLATION INSTRUCTIONS:

• It should be used exclusively in accordance with intended use.

• Mount exclusively in specialized workshops.

• The connection between the lamp and vehicle's installation should be isolated with heat-shrink tube, or, alternatively, with isolating tape, to avoid getting water and moisture to the copper wire of the lamp, which can damage electronic components. When it comes to lamp and plug, the plug should be mounted safely.

• Do not cut off tinned ends.

• Lamps must be installed only in accordance with UNECE regulations

* Two level of intensity (Class 2) in Amber Applying yellow wire touch to red wire 1-3 seconds will activate the effective intensity "By night"

We reserve the right to change technical data and any errors. Photos and specifications are for reference only, and the actual product may vary slightly. Reproduction in whole or parts of the catalog without written authorization is prohibited.



www.truck-kamar.pl



REFERENCE:
BLK0029

COUNTRY OF ORIGIN: PRC

WARNINGS FOR THE USER:

Warning!

-Do not look directly into the light - it may cause damage or even loss of vision.

-Install only in specialized workshops or professional services.

- Use in open space only.

- Use in accordance to the purpose.

LED WARNING LIGHTBAR 1235X220 R10 R65 TA2

PHOTO AND TECHNICAL DRAWING:

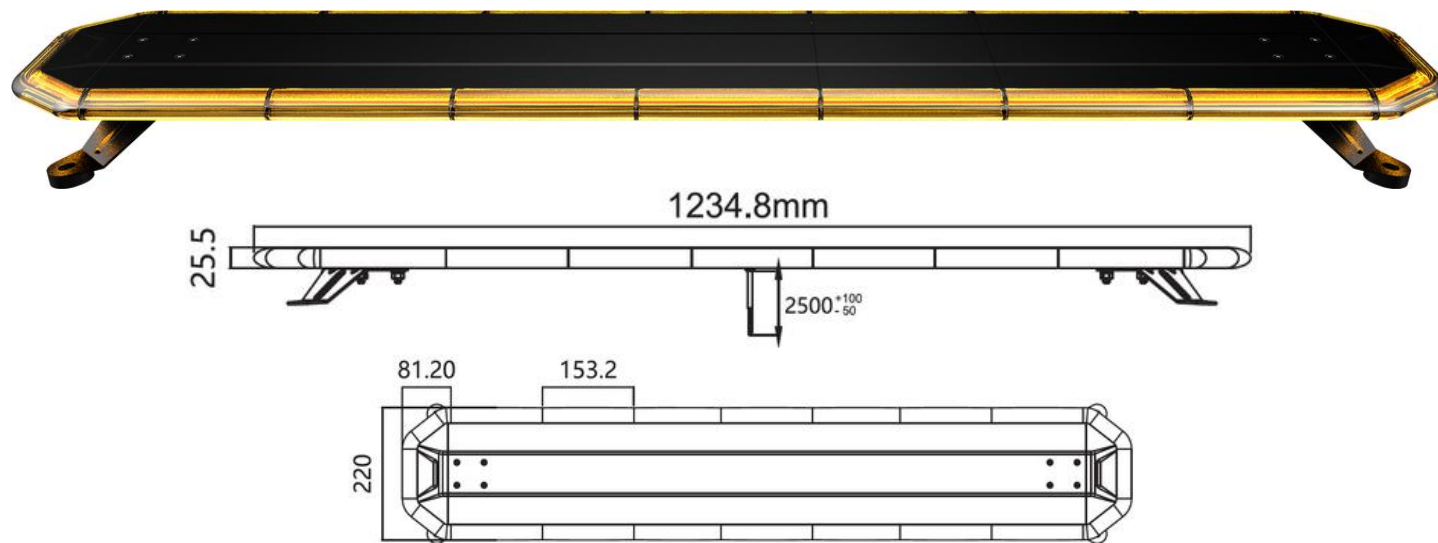

TECHNICAL SPECIFICATIONS:

MATERIAL	LED QUANTITY	MOUNTING	CABLE	FUNCTION	WATT	VOLTAGE	CERTIFICATES	PACKING/WEIGHT
» Lens: PC » Housing: AL	» 20	» screws	» 5000mm	» 1 warnings flashes, » two level of intensity, day and night	» 178W	» 12V/24V	» ECE R65 » ECE R10	» cart.dim.: 1500x300x50 mm » lamp weight: 7220g » 1 pc/bulk box

INSTALLATION INSTRUCTIONS:

• It should be used exclusively in accordance with intended use.

• Mount exclusively in specialized workshops.

• The connection between the lamp and vehicle's installation should be isolated with heat-shrink tube, or, alternatively, with isolating tape, to avoid getting water and moisture to the copper wire of the lamp, which can damage electronic components. When it comes to lamp and plug, the plug should be mounted safely.

• Do not cut off tinned ends.

• Lamps must be installed only in accordance with UNECE regulations

* Two level of intensity (Class 2) in Amber Applying yellow wire touch to red wire 1-3 seconds will activate the effective intensity "By night"

We reserve the right to change technical data and any errors. Photos and specifications are for reference only, and the actual product may vary slightly. Reproduction in whole or parts of the catalog without written authorization is prohibited.



www.truck-kamar.pl



REFERENCE:
BLK0030

COUNTRY OF ORIGIN: PRC

WARNINGS FOR THE USER:

Warning!

-Do not look directly into the light - it may cause damage or even loss of vision.

-Install only in specialized workshops or professional services.

- Use in open space only.

- Use in accordance to the purpose.

LED WARNING LIGHTBAR 1540X220 R10 R65 TA2

PHOTO AND TECHNICAL DRAWING:

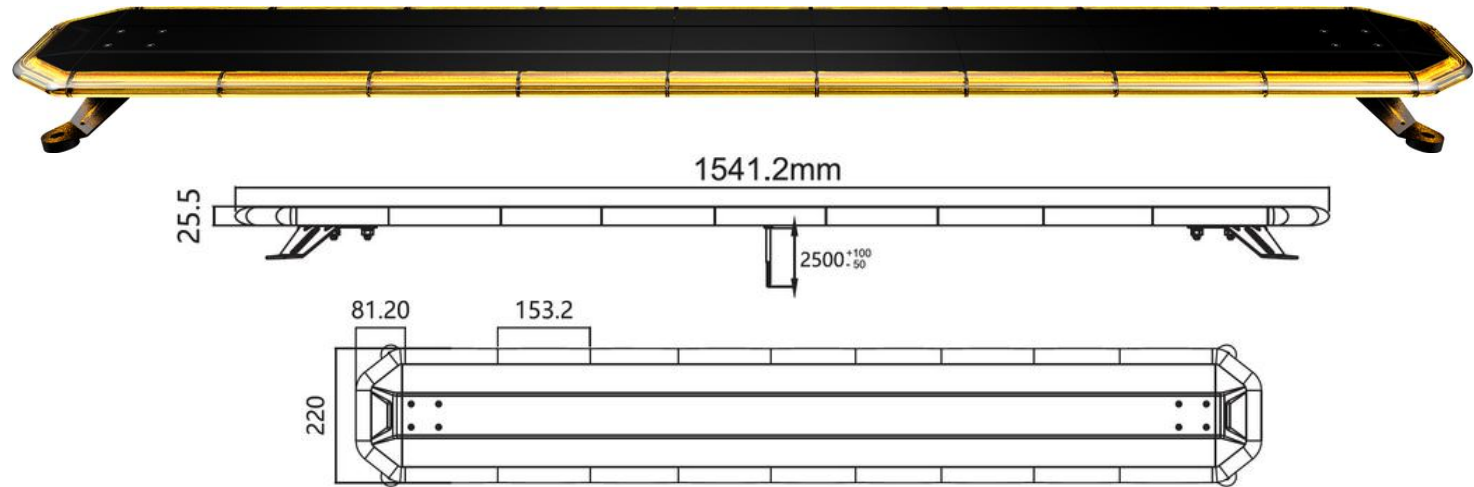

TECHNICAL SPECIFICATIONS:

MATERIAL	LED QUANTITY	MOUNTING	CABLE	FUNCTION	WATT	VOLTAGE	CERTIFICATES	PACKING/WEIGHT
» Lens: PC » Housing: AL	» 24	» screws	» 5000mm	» 1 warnings flashes, » two level of intensity, day and night	» 188W	» 12V/24V	» ECE R65 » ECE R10	» cart.dim.: 1800x300x50 mm » lamp weight: 8730g » 1 pc/bulk box

INSTALLATION INSTRUCTIONS:

· It should be used exclusively in accordance with intended use.

· Mount exclusively in specialized workshops.

· The connection between the lamp and vehicle's installation should be isolated with heat-shrink tube, or, alternatively, with isolating tape, to avoid getting water and moisture to the copper wire of the lamp, which can damage electronic components. When it comes to lamp and plug, the plug should be mounted safely.

· Do not cut off tinned ends.

· Lamps must be installed only in accordance with UNECE regulations

* Two level of intensity (Class 2) in Amber Applying yellow wire touch to red wire 1-3 seconds will activate the effective intensity "By night "

We reserve the right to change technical data and any errors. Photos and specifications are for reference only, and the actual product may vary slightly. Reproduction in whole or parts of the catalog without written authorization is prohibited.



www.truck-kamar.pl



REFERENCE:
BLK0031

COUNTRY OF ORIGIN: PRC

WARNINGS FOR THE USER:

Warning!

-Do not look directly into the light - it may cause damage or even loss of vision.

-Install only in specialized workshops or professional services.

- Use in open space only.

- Use in accordance to the purpose.

LED WARNING LIGHTBAR 20W R10 R65 MAGNET

PHOTO AND TECHNICAL DRAWING:

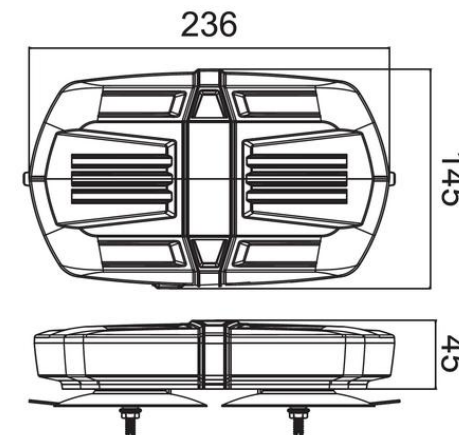

TECHNICAL SPECIFICATIONS:

MATERIAL	LED QUANTITY	MOUNTING	CABLE	FUNCTION	WATT	VOLTAGE	CERTIFICATES	PACKING/WEIGHT
» Lens: PC » Housing: AL	» 32	» magnet	» 2500mm with cigarette lighter plug	» 1 warnings flashes	» 23W	» 12V/24V	» ECE R65 » ECE R10	» cart.dim.: 390x265x56mm » lamp weight: 1000g » 8 pc/bulk box

INSTALLATION INSTRUCTIONS:

· It should be used exclusively in accordance with intended use.

· Mount exclusively in specialized workshops.

· The connection between the lamp and vehicle's installation should be isolated with heat-shrink tube, or, alternatively, with isolating tape, to avoid getting water and moisture to the copper wire of the lamp, which can damage electronic components. When it comes to lamp and plug, the plug should be mounted safely.

· Do not cut off tinned ends.

· Lamps must be installed only in accordance with UNECE regulations

-- Only mount the lamp to a flat, metal, dry, cleaned and degreased roof surface. The maximum speed of movement of the vehicle with a warning lamp attached with a magnet to the roof surface is 50km / h. Take special care in windy conditions. Do not unscrew the lamp, it will lose its water resistance.

We reserve the right to change technical data and any errors. Photos and specifications are for reference only, and the actual product may vary slightly. Reproduction in whole or parts of the catalog without written authorization is prohibited.



www.truck-kamar.pl



Al. Armii Krajowej 254
85-689 Bydgoszcz, Poland
tel: +48 52 326 71 50
fax: +48 52 326 71 58
info@truck-kamar.pl

www.truck-kamar.pl